

No	Description		Part Pièce
A	Pressure balanced diverter valve	Valve à pression équilibrée / déviateur	N/A
A-1	Handle kit	Ensemble de poignée	FCKTS2180MG
A-2	Index	Index	FCHDL4018MG
A-3	Allen screw	Vis Allen	FCSCR2002
A-4	Trim Cap	Garniture d'écrou	FCDEC4007MG
A-5	Trim sleeve	Douille de finition	FCDEC5005MG
A-6	Plate screw	Vis de la plaque de finition	FC94680-7A
A-7	Wall plate	Plaque murale	FCOTH9058
A-8	Diverter trim sleeve	Douille de finition de l'inverseur	FCDEC5023MG
A-9	Face plate with seal joint	Plaque de finition avec joint d'étanchéité	FCDEC7124MG
A-10	Friction washer	Rondelle	FCWAA1029MG
A-11	Diverter handle kit	Ensemble de poignée pour inverseur	FCKTS2181MG
A-12	Index	Index	FCHDL4017MG
A-13	Threaded Sleeve	Douille filetée	FCOTH9059
A-14	Ceramic cartridge	Cartouche céramique	FC9AC010-2
A-15	Check/stop valves kit	Ensemble de soupapes d'arrêt et anti-retour	FCVALA014
A-16	Washer	Rondelle	FCWAA1013
A-17	Nut	Écrou	90644
A-18	Diverter	Inverseur	FCCARD012
A-19	Diverter retaining nut	Écrou de retenu de l'inverseur	N/A
A-20	Valve	Valve	N/A
B	Sliding bar kit with flexible hose	Ensemble de barre à glissière et boyau	B90-730MG
B-1	Flexible hose	Boyau	96179MG-P
B-2	Hand shower holder	Support pour douche à main	B93-700MG
B-3	Wall support	Support murale	B93-701MG
B-4	End cap wall support	Embout du support murale	B93-702MG
C	Hand shower	Douche à main	FCSPS2047MG
D	Water supply elbow	Coude d'alimentation	B92-002MG
E	Shower arm and flange kit	Ensemble de bras et bride de douche	FCDEC0005MG
F	Shower head	Pomme de douche	FCSPS3047MG

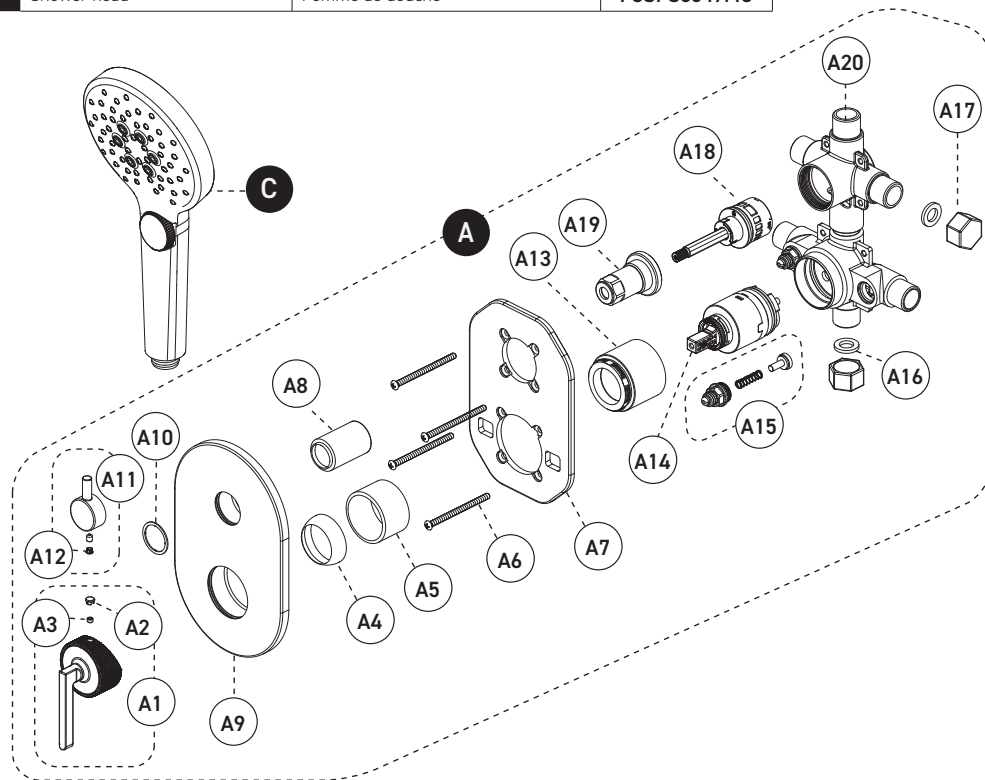

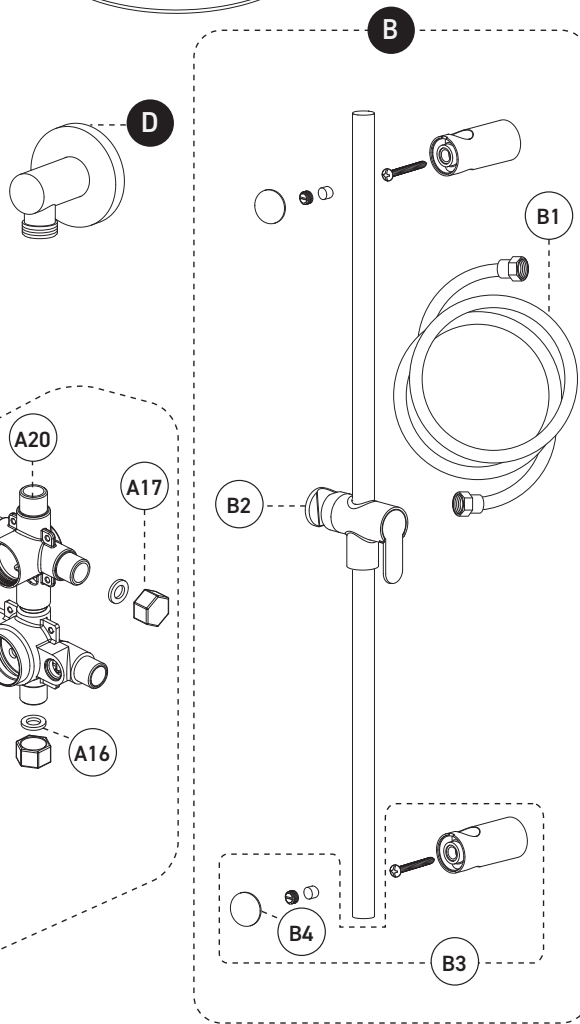
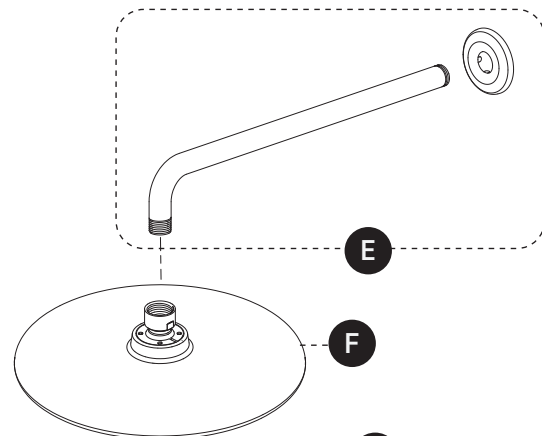

IMPORTANT

Bélanger recommends using a professional plumber for all installation and repair. Please inform yourself about the Canadian Plumbing Code's regulations and your local municipality plumbing codes before installation. The Canadian Plumbing Code requires the installation of surge arresting devices to eliminate water hammering. **ALLOW AN ADEQUATE OPENING IN ORDER TO EASILY ACCESS CONNECTIONS OR OTHER PLUMBING DEVICES FOR MAINTENANCE OR REPAIR.**

Bélanger recommande de faire appel à un plombier compétent pour l'installation et la réparation de ce produit. Veuillez vous informer des différentes règles du Code Canadien de plomberie et des exigences de votre localité avant l'installation. Le Code Canadien de plomberie exige l'installation d'un dispositif anti-bélier afin d'amortir les coups de bélier dans la plomberie. **PRÉVOIR UNE OUVERTURE SUFFISANTE POUR FACILITER L'ACCÈS AUX RACCORDEMENTS OU À TOUT AUTRE DISPOSITIF DE PLOMBERIE EN VUE DE L'ENTRETIEN OU DE LA RÉPARATION.**

essentialStyle

by par **bélanger**

SHOWER FAUCET - COMPLETE MODEL ROBINET POUR DOUCHE - MODÈLE COMPLET KIT-IND230CMG

RECOMMENDED TOOLS / OUTILS RECOMMANDÉS

Plumber's putty
Mastic pour
plombier*



Thread seal tape
Ruban d'étanchéité
pour joints filetés**



Included / Inclus



* Apply plumber's putty under the plastic cover deck plate to seal your installation.

Appliquez du mastic pour plombier sous la sous-plaque de plastique pour rendre votre installation étanche.

** Apply thread seal tape on threaded connections.

Appliquez du ruban d'étanchéité sur les connexions filetées.

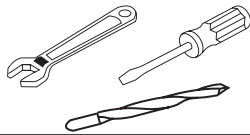

For warranty and to register your product
Garantie et enregistrement de votre produit

belangerh2o.com



CARE INSTRUCTIONS

Rinse the product with clear water.
Dry the product with a soft cloth.

DO NOT:

Use abrasive cleansers, cloths, or paper towels. Use any cleaning agents containing acid, polish, wax, alcohol, ammonia, bleach, solvent or any other corrosive or harsh chemical cleansers.

INSTRUCTIONS D'ENTRETIEN

Rincer le robinet avec de l'eau claire et l'essuyer avec un tissu doux.

À NE PAS FAIRE:

Utiliser des tissus ou essuie-tout abrasifs, produits nettoyants contenant de l'acide, agent polisseur, cires, alcool, ammoniaque, eau de Javel, solvants ou tout autres produits chimiques corrosifs.

The model shown in the installation steps may differ from the one in box however connection type and installation steps are the same.

Le modèle démontré dans les étapes d'installation peut différer du produit en boîte, mais le type de connexions et d'installation demeure le même.

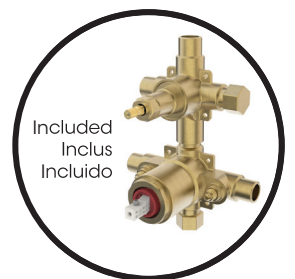

Customer Service

Monday to Friday:
8 a.m. - 4:30 p.m. E.S.T.

Tel: **1-800-361-5960**

Service à la clientèle

Lundi au vendredi:
8 h 00 à 16 h 30 H.N.E.

Fax: **1-888-533-8313**

info@belangerh2o.com

Replacement parts are available on order
Les pièces de remplacement sont disponibles sur commande

Before you begin / Avant de commencer

Technical drawing - Dessin technique (KIT-IND230CMG)

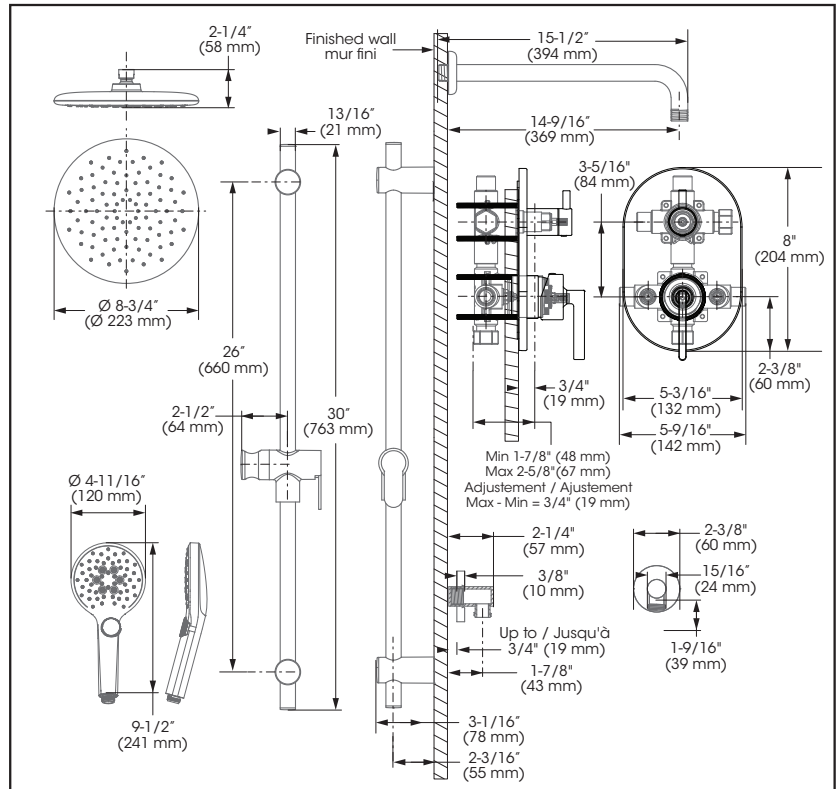
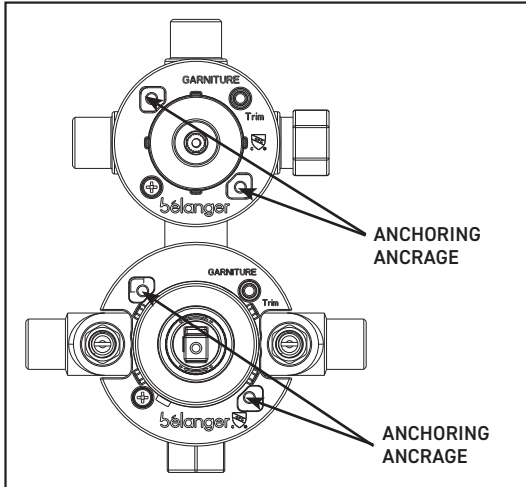
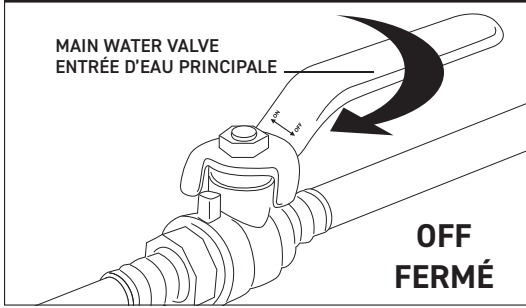

Installation steps - Étapes d'installation

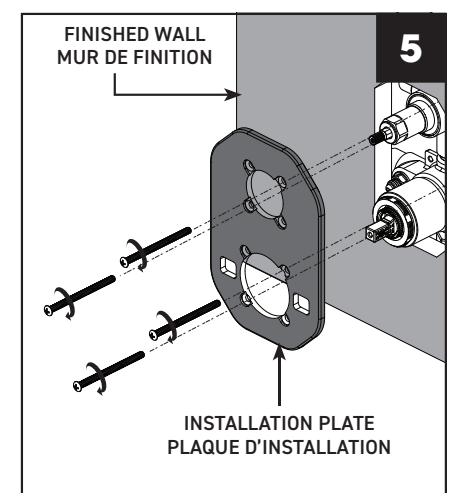
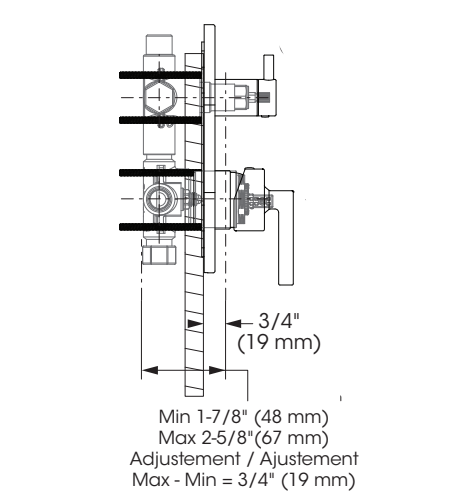
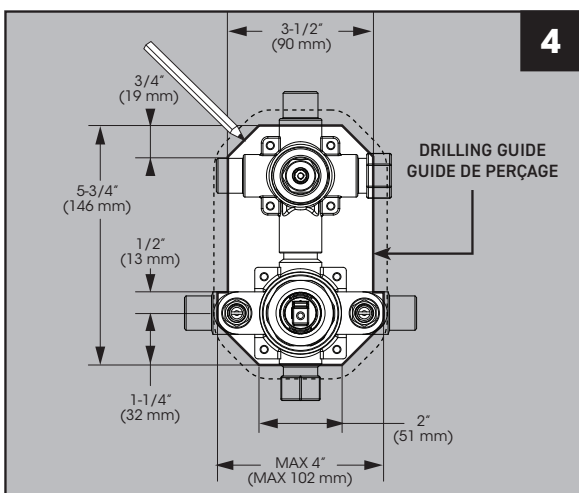
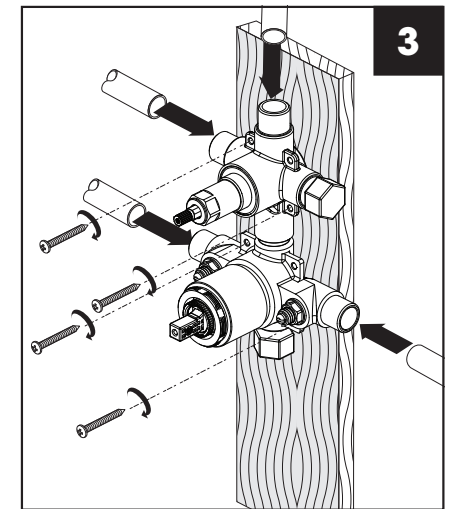
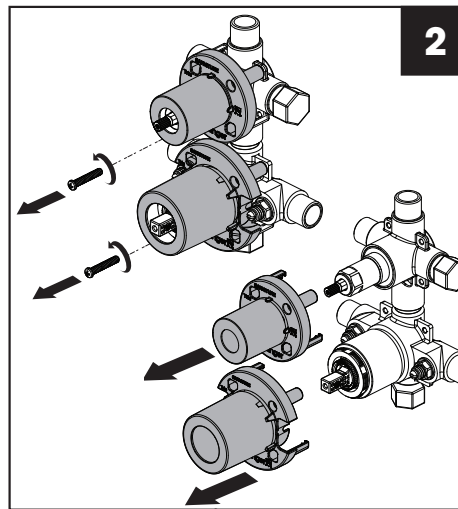
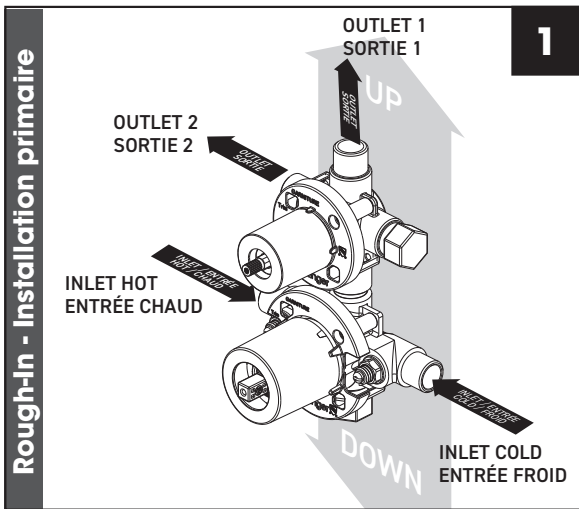

Installation steps - Étapes d'installation

Valve Trim - Garniture valve

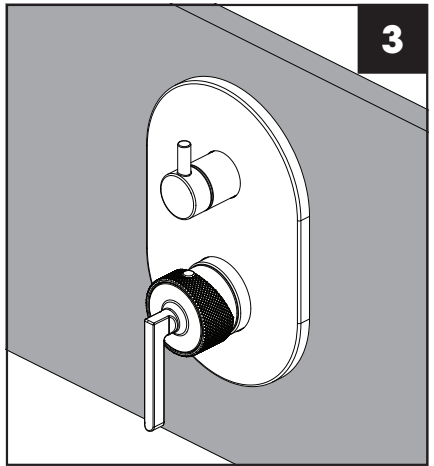
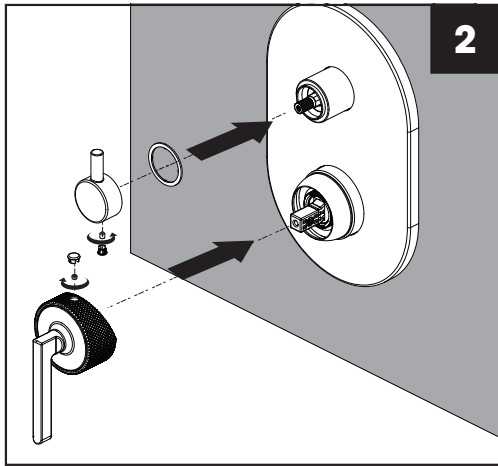
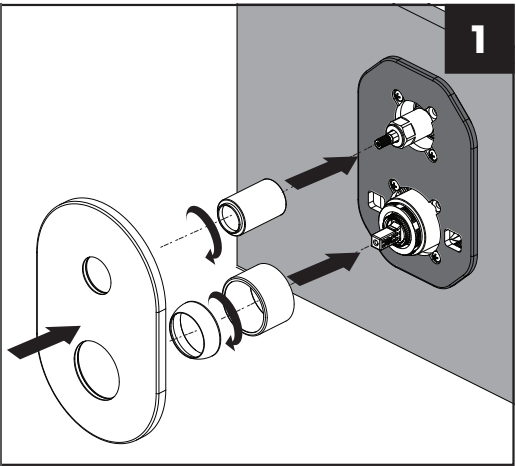

Sliding Bar - Barre à glissière

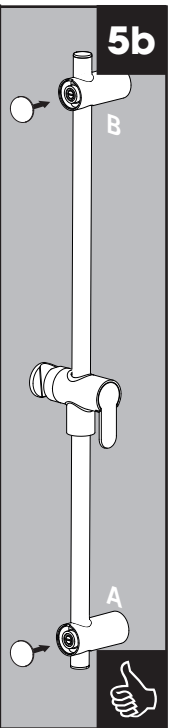
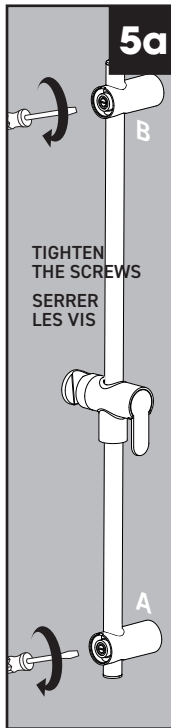
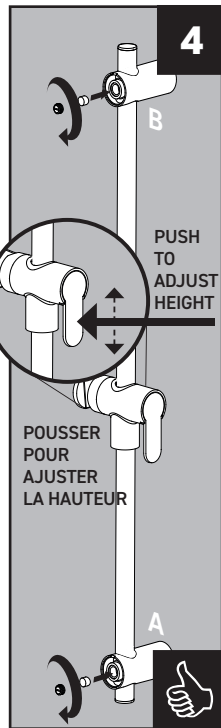
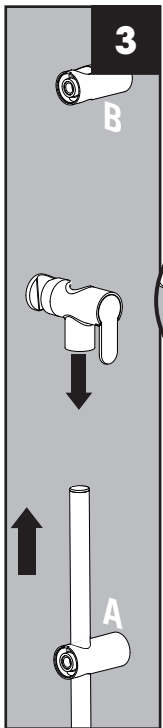
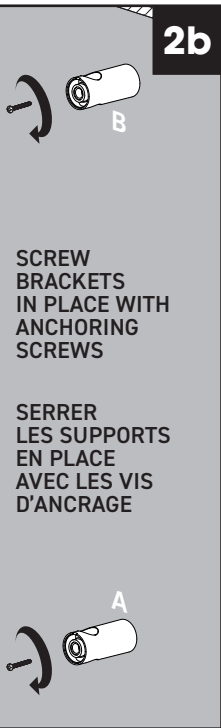
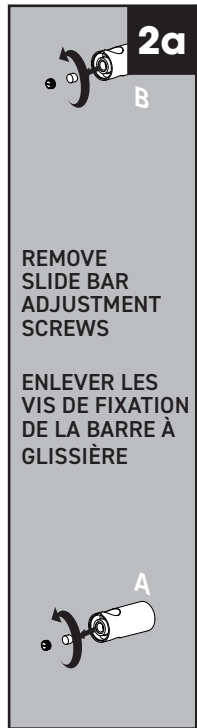
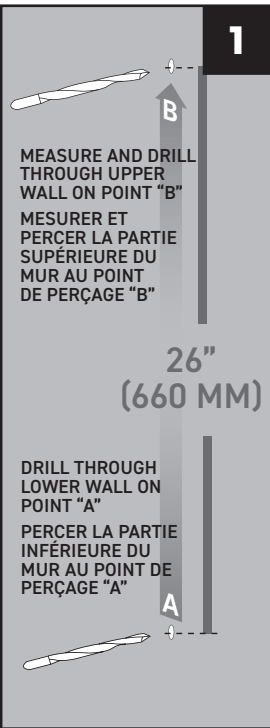

Water supply elbow
Coude d'alimentation

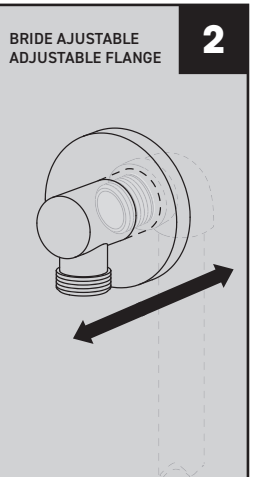
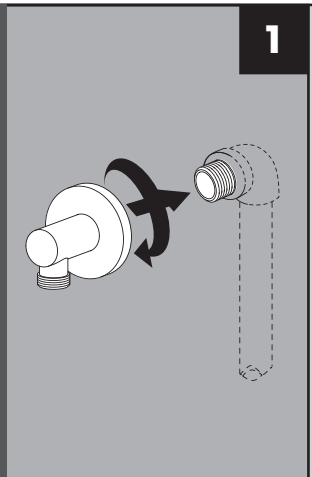

Hand shower and hose
Douche à main et boyau

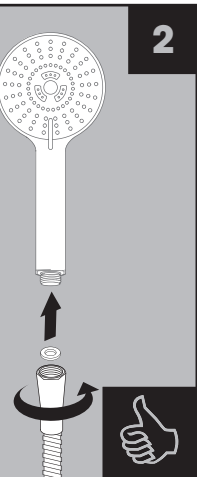
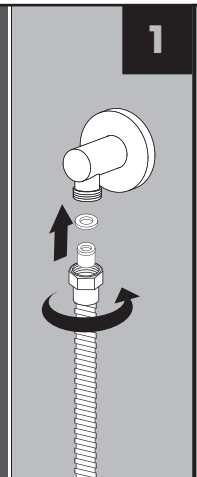

Shower Head - Pomme de douche

